



PRICELIST

VALID TILL DECEMBER 2023



READY BUSINESS SOLUTION OPPORTUNITY
TO WORK WITHOUT RESTRICTIONS



Starting from
£65,900

FUTURISTO Max

8190x2440x3000

Bearing Capacity:

3500 kg, Wheels: 4xR14

Body:

Fiberglass

Floor:

Subfloor of waterproof lamination plywood.

Entrance door window:

1750x850 mm, 2pcs.

The window is closed with anti-vandal shutters. It is equipped with a gas lid/holding system.

A window for TV installation dimensions:

1250x850 mm.

All the documents for registration are available.



ISO 9001-2015



SUSPENSION SYSTEM

Knott (Germany)



TRAILER SHOWCASE

Two sliding glass window opening



CHASSIS

Stainless steel - 3 mm



WALLS

Outside and inside - fiberglass with insulation 5mm



BODY COLOUR

Gelcoat, all RAL colors



PARKING LIGHTS

+359 877 999 377 hello@futuristotrailers.com



www.futuristotrailers.com



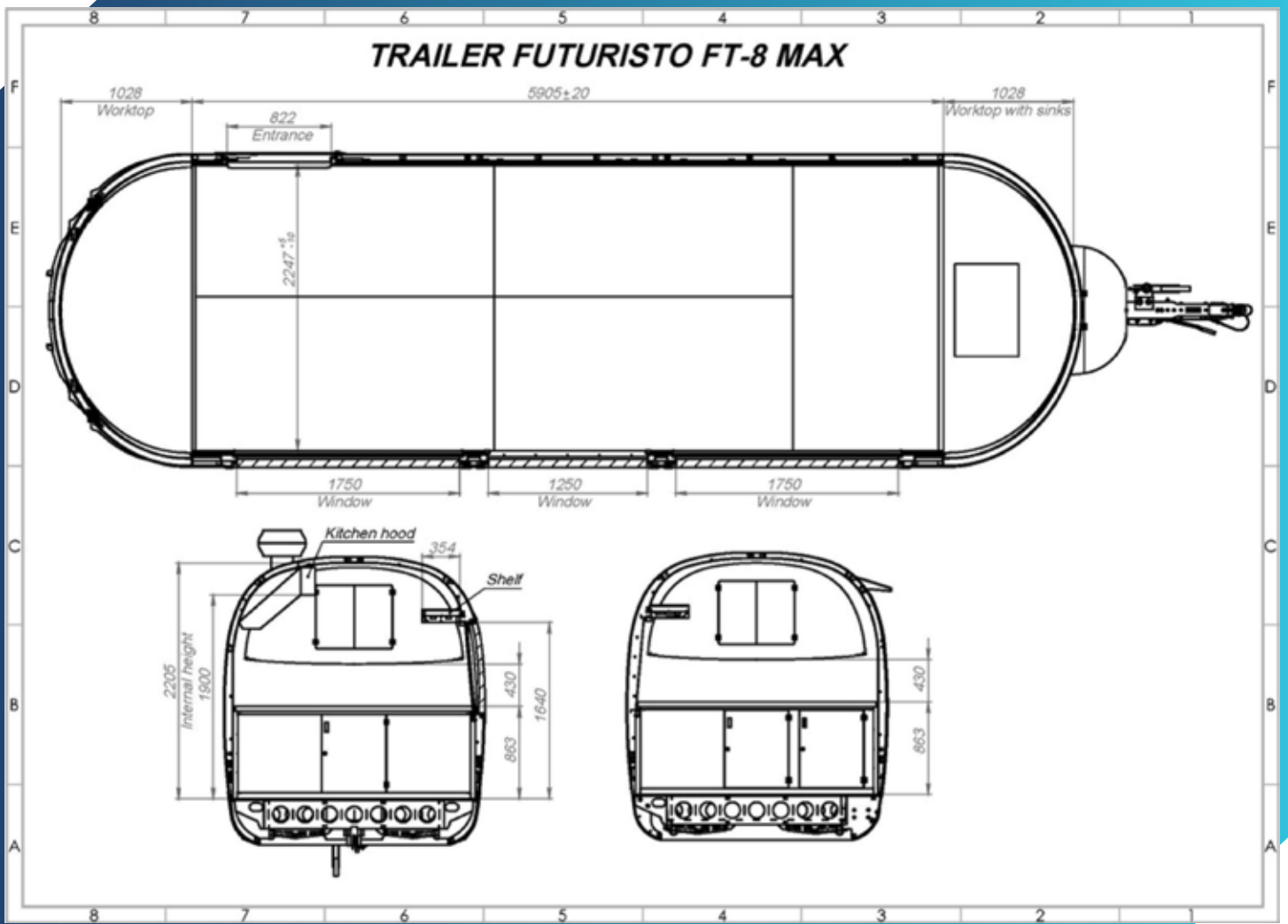

Food Trailer Max

8190x2440x3000



+359 877 999 377



hello@futuristotrailers.com



www.futuristotrailers.com





Starting from
£56,900

FUTURISTO Medium

6250x2440x3000

Bearing Capacity:

3500 kg, Wheels: 4xR14

Body:

Fiberglass

Floor:

Subfloor of waterproof lamination plywood.

Entrance door window:

1750x850 mm, 1pcs. 1250x850 mm, 1pcs.
The window is closed with anti-vandal shutters.
It is equipped with a gas lid/holding system.



ISO 9001-2015



SUSPENSION SYSTEM

Knott (Germany)



TRAILER SHOWCASE

Two sliding glass window opening



CHASSIS

Stainless steel - 3 mm



WALLS

Outside and inside - fiberglass with insulation 5mm



BODY COLOUR

Gelcoat, all RAL colors



PARKING LIGHTS

All the documents for registration are available.

+359 877 999 377 hello@futuristotrailers.com



www.futuristotrailers.com



Dimensional diagram Trailer FUTURISTO FT-6 Medium

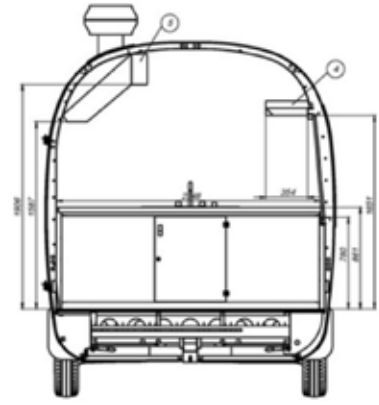
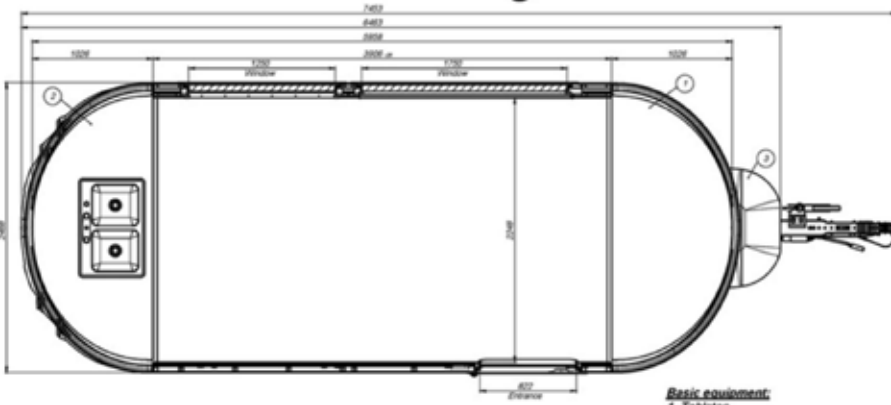

- Basic equipment:**
1. Tabletop
 2. Countertop with built-in double sink and faucet
 3. Gas compartment for 2 cylinders of 20 liters with LPG
 4. Hanging shelf
 5. Hood(L=2000 mm) with two fans
 6. Electrical panel (conditionally not shown)

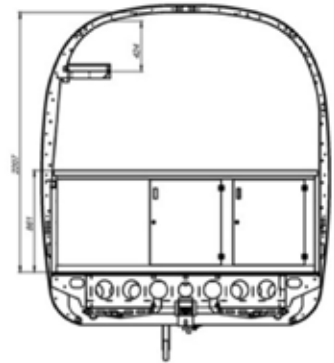
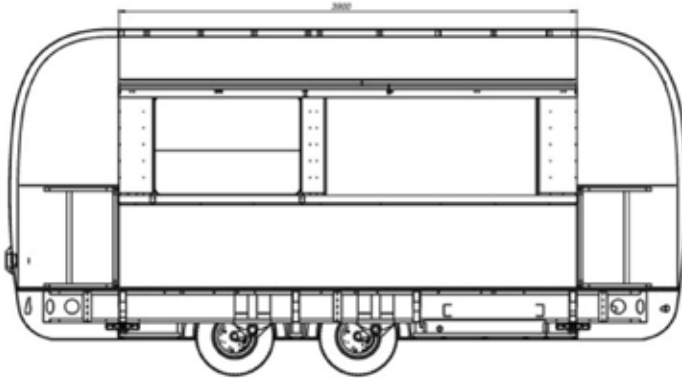

M 1:15

THE INFORMATION CONTAINED IN THIS DRAWING IS THE SOLE PROPERTY OF FUTURISTO TRAILERS. ANY REPRODUCTION IN PART OR AS A WHOLE WITHOUT THE WRITTEN PERMISSION OF FUTURISTO TRAILERS IS PROHIBITED.



Food Trailer Medium

6250x2440x3000

+359 877 999 377 hello@futuristotrailers.com

www.futuristotrailers.com





Starting from
£47,900

FUTURISTO Mini

4050x2440x3000

Bearing Capacity:

1800 kg, Wheels: 2xR14

Body:

Fiberglass

Floor:

Subfloor of waterproof lamination plywood.

Entrance door window:

1750x850 mm, 1pcs.

The window is closed with anti-vandal shutters.
It is equipped with a gas lid/holding system.



ISO 9001-2015



SUSPENSION SYSTEM

Knott (Germany)



TRAILER SHOWCASE

Two sliding glass window opening



CHASSIS

Stainless steel



WALLS

Outside and inside - fiberglass with insulation 5mm



BODY COLOUR

Gelcoat, all RAL colors



PARKING LIGHTS

All the documents for registration are available.

+359 877 999 377 hello@futuristotrailers.com

 www.futuristotrailers.com



Dimensional diagram Trailer FUTURISTO FT-4 Mini

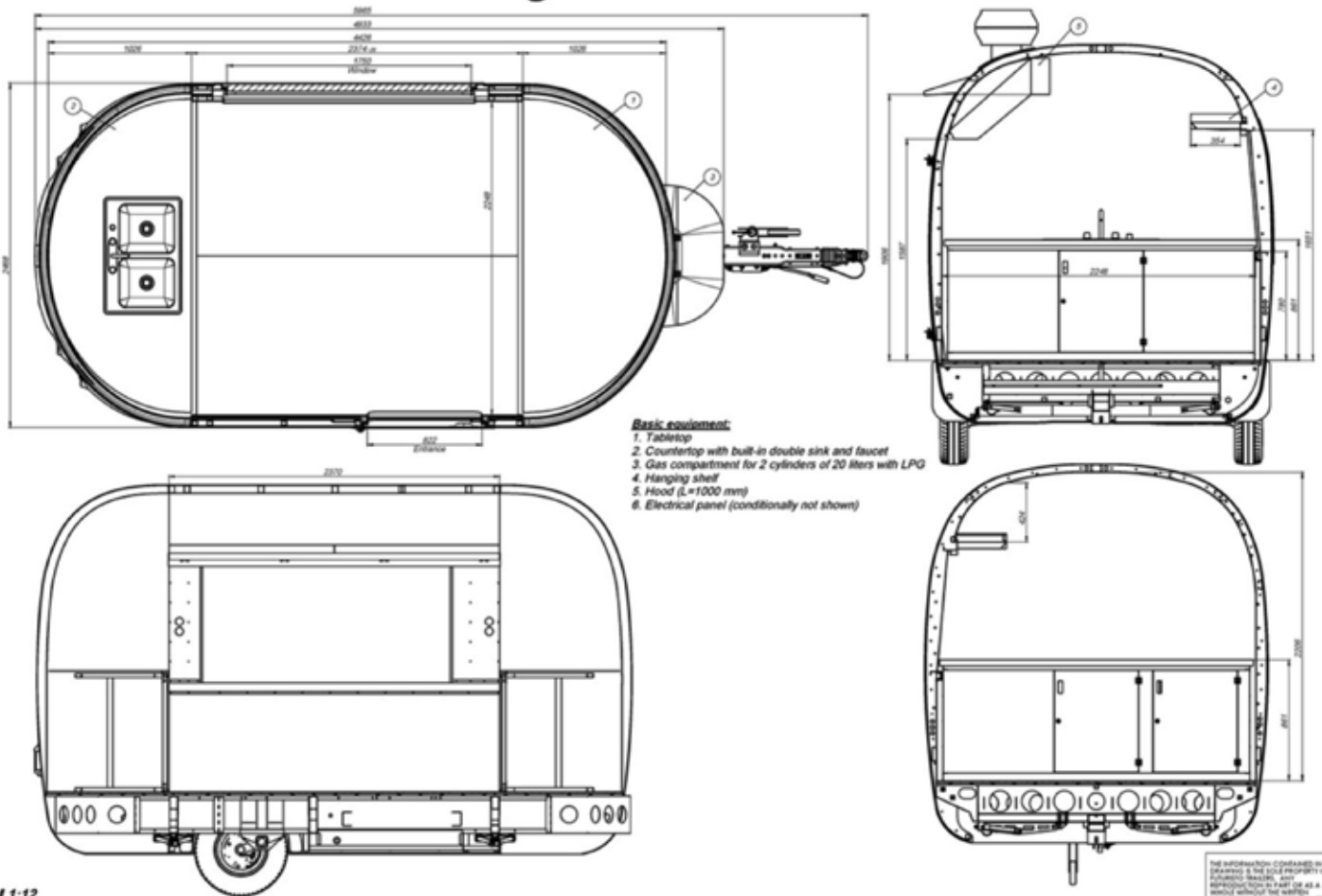

Food Trailer Mini

4050x2440x3000

+359 877 999 377 hello@futuristotrailers.com

 www.futuristotrailers.com



EQUIPMENT INCLUDED IN PRICE



Power Supply

Voltage 220/380 V

Electrical Switchboard with protective automatics.

Sockets (2x2; 2x3; 2x4) are installed in a working area.

Power from an external source

A socket is installed in the special place in the hatch mono or two-phase voltage.



Water supply and grey water system

External water connection and water outlet

EQUIPMENT INCLUDED IN PRICE



Floor

Quartz-vinyl coating

Inside Lighting

LED Lighting: 6,5,4 meter each

LED visor on exhaust hoods



Outside Lighting

LED lighting per perimeter

4,2 visor on a shopping window



+359 877 999 377



hello@futuristotrailers.com



www.futuristotrailers.com



ADDITIONAL OPTIONS



LPG bottle box and an external source

LPG bottle box located in the front part

£ 800

Kitchen Hood

An exhaust hood with grease traps and grease drains is installed on the wall. Stainless steel.

The length of the exhaust hood is 2000, 1000 mm

come with

Kitchen wall covering

Kitchen wall covering of stainless steel under an system lenght:2,1 meters

Max £ 1000

Medium £ 1000

Mini £ 500



ADDITIONAL OPTIONS



Ventilation

An Exhaust system engine
Volume: 2300, 1150 m³/h

Max **£ 800**

Medium **£ 800**

Mini **£ 400**

Built-in Washing Cabinet

2 sinks with cranes built-in into the countertop stainless steel covering

Dimensions of the sink:
750/530 2pcs

£ 625



Bilt-in cabinet in a semisphere

Cabinet with countertop stainless steel covering

£ 550



ADDITIONAL OPTIONS



Shelf

Convenient hanging shelves Material - stainless steel, Length: 6,4,2 meters

Max **£ 700**

Medium **£ 450**

Mini **£ 300**

Air Conditioner

£ 1000



Wheels Caps

Wheels caps base trailer color

Max **£ 200**

Medium **£ 200**

Mini **£ 100**



ADDITIONAL OPTIONS



Waste Water Tank

Volume: 100L

Dimensions: 660x480x480

£ 200

Water Tank Hydrophoric Pump 12V

Volume: 100L

Dimensions: 660x480x440

£ 500





+359 877 999 377



hello@futuristotrailers.com



www.futuristotrailers.com





+359 877 999 377



hello@futuristotrailers.com



www.futuristotrailers.com